

DSchmidt Technologies' 8 Channel DTMF to RS232 Decoder (part # 8CH-DTMF)

Overview

This 8 channel DTMF to RS232 decoder will decode DTMF tones from 8 independent audio sources and send its ASCII value out the RS232 port. The serial port is configured at 19200 baud, 8bits, no parity, 1 stop bit.

Features

- In assembled form. Hook up the audio input and a power supply and it's ready!
- True RS232 output voltages
 - o On board RS232 DB9F connector
 - o RS232 19200,8,n,1 baud output
- On board RCA audio input connector X 8
 - o Minimum tone ON/OFF durations of 40mS/40mS
- Channel LED tells you when a valid tone is decoded and from a particular channel
- Wide power input voltage range (7-20 VDC), 60mA current draw
 - o Green power LED shows when power is applied
 - o On board DC input jack accepts 5.0mm x 2.1mm plugs and is auto polarity sensing

Hookup

The unit comes assembled and is tested before shipment. An external wall adapter supplying a voltage between 7 to 20VDC and of at least 100mA should be used. The DC power jack accepts a 5.0mm x 2.1mm plug and is auto polarity sensing.

The user must hook up the audio input to the desired source. The on-board phono jack accepts line level audio input. Connect this jack directly to your audio source. **DO NOT CONNECT A TELEPHONE LINE DIRECTLY TO THIS JACK!** The voltage levels from a telephone line are too great to be used directly.

If you wish to hook this decoder to your phone line and a computer at the same time, you will need to do so using a 1:1 isolation transformer (also known as a 600:600 phone transformer). This will electrically isolate the two from each other. See sample circuit shown later in this document. Each channel will require its own isolation transformer.

Circuit Board Layout with Audio and Power Connection Locations

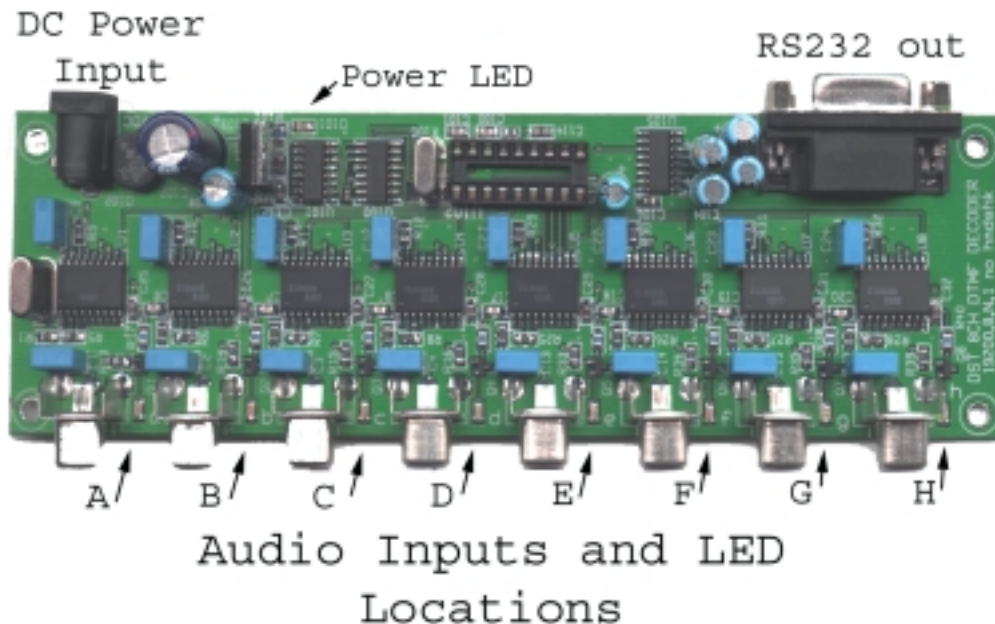

RS232 Connection

The on-board DB9F connector is configured as a standard, transmit only, PC serial port. All handshaking lines have been jumpered together. Communication is performed at 19200 baud, 8 bits, no-parity, 1 stop bit.

Operation

As tones are received on a particular channel, the LED for that channel will light for the duration of the tone. The tone will then be decoded and the ASCII value of this tone will be sent via the RS232 port, preceded by the channel ID. The table below shows what the unit will output for a given DTMF tone on a given channel.

DTMF Tone	Input Channel							
	a	b	c	d	e	f	g	h
1	a1	b1	c1	d1	e1	f1	g1	h1
2	a2	b2	c2	d2	e2	f2	g2	h2
3	a3	b3	c3	d3	e3	f3	g3	h3
4	a4	b4	c4	d4	e4	f4	g4	h4
5	a5	b5	c5	d5	e5	f5	g5	h5
6	a6	b6	c6	d6	e6	f6	g6	h6
7	a7	b7	c7	d7	e7	f7	g7	h7
8	a8	b8	c8	d8	e8	f8	g8	h8
9	a9	b9	c9	d9	e9	f9	g9	h9
0	a0	b0	c0	a0	e0	f0	g0	h0
#	a#	b#	c#	a#	e#	f#	g#	h#
*	a*	b*	c*	d*	e*	f*	g*	h*
A	aA	bA	cA	dA	eA	fA	gA	hA
B	aB	bB	cB	dB	eB	fB	gB	hB
C	aC	bC	cC	dC	eC	fC	gC	hC
D	aD	bD	cD	dD	eD	fD	gD	hD

Two digits are sent out the RS232 port for every tone received, the first of which is the channel ID, the second is the DTMF ID.

For Assembled/Tested Products: WARRANTY

DSchmidt Technologies expressly warrants that it will either repair or replace the 8CH_DTMF Decoder if it proves to be defective in design, material, or workmanship within ninety (90) days from the buyer's date of purchase.

For warranty repair or replacement, the defective 8CH_DTMF Decoder must be returned within ninety (90) days to DSchmidt Technologies by insured mail and accompanied by proof of purchase. A repaired or replacement 8CH_DTMF Decoder shall be warranted as above for the balance of the original product Warranty Period or thirty (30) days, whichever is longest.

DSchmidt Technologies shall have no obligation with respect to any Product which has been modified or altered. In no event shall DSchmidt Technologies be liable for consequential damages, losses, or expenses arising out of this transaction. The return of the purchase price or the repair or replacement of the product shall be the buyer's sole remedy hereunder.

This limited warranty is DSchmidt Technologies sole warranty. DSchmidt Technologies makes no other warranty of any kind whatsoever, express or implied. All implied warranties of merchantability and/or fitness for a particular purpose are hereby disclaimed by DSchmidt Technologies.

For ALL Products: SOFTWARE RIGHTS

The software programs that controls the 8CH_DTMF Decoder manufactured by DSchmidt Technologies is solely owned by DSchmidt Technologies and all rights are reserved. Reproduction, adaptations, or translation of those programs without prior written permission of DSchmidt Technologies is prohibited.

Board Dimensions

